

## Potain HD 21A

### Dimensions

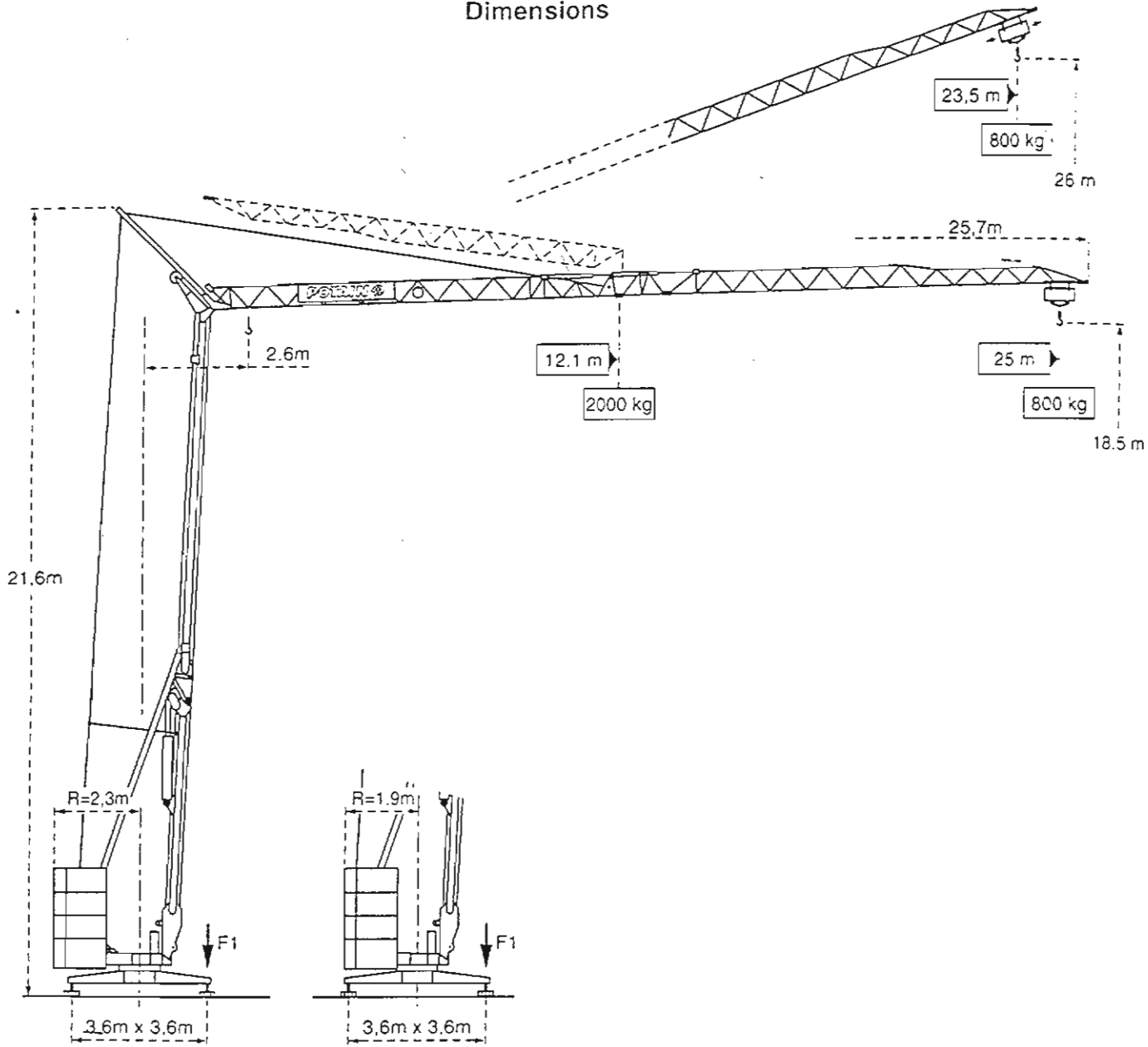

F1 =			Reactions		
F1 (R = 2.3 m)	● 12.3 t	■ 6.8 t	F1 (R = 1.9 m)	● 13.4 t	■ 7.9 t
			⊗	7.4 t	

- In service
- Out of service

⊗ Without load, ballast or transport axles, with maximum jib and maximum height.

## Potain HD 21A

### Load diagrams



Jib

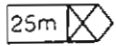

	12.1	13	14	15	16	17	18	19	20	21	22	23	24	25	m
25m	2000	1825	1660	1525	1405	1300	1210	1135	1060	1000	940	890	845	800	Kg

### Luffing jib

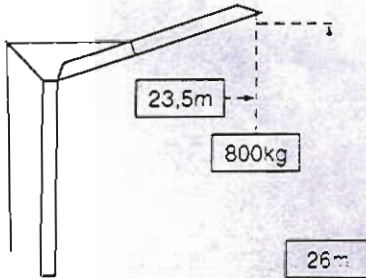

Trolley locked

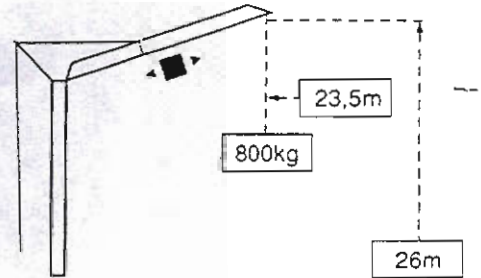

Traversing trolley

### Erection

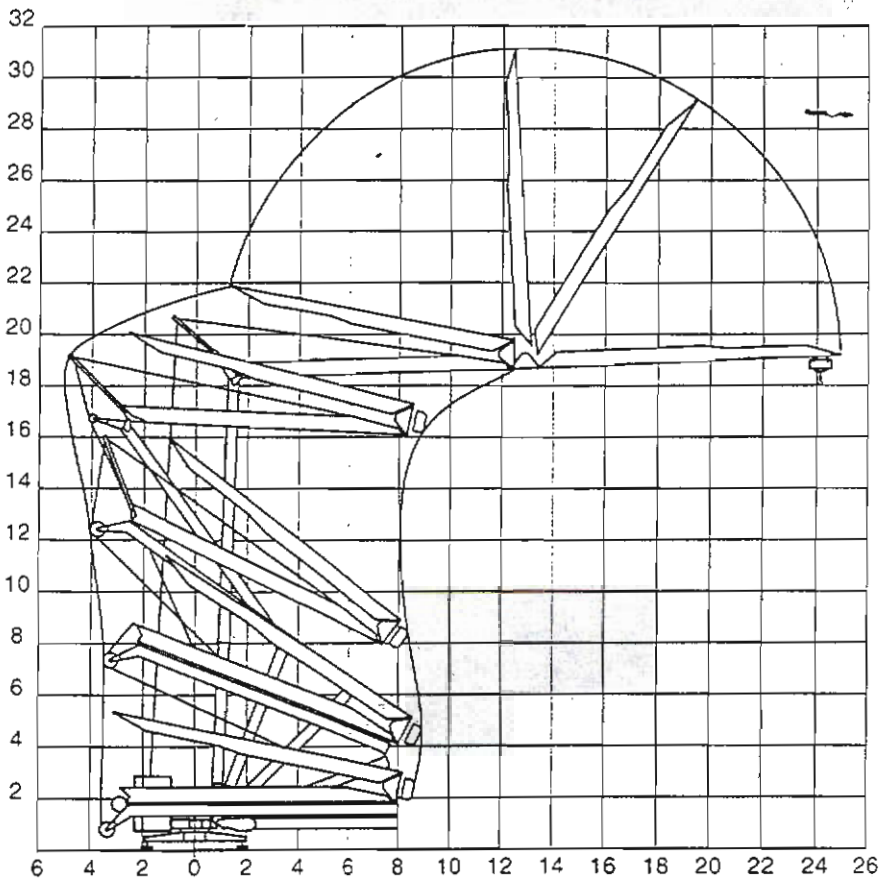

## Potain HD 21A

### Mechanisms

				m/min	kg	ch-PS hp	kW
Hoisting	▲ ● ▼	9 PC 10		5,7	2000	2,7	2
				17,5	2000	8,2	6
				35	1000	8,2	6
Trolleying	◀ ■ ▶	1 D1 V1 C	36	18 - 36		1,2	0,9
		2 D2 V4				2	1,5
Stewing	⦿	RCO 11	0 - 0,3 - 0,9 tr/min - U/min - rpm			1,5	1,1
Mains supply						380V - 50Hz	
Necessary electric power						12 kVA	

### Transport

18/27  
15A/25A  
14A/21A

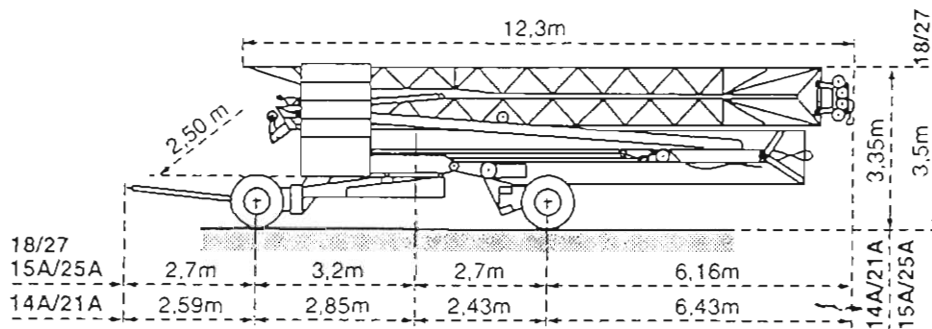

DJ125/S105  
DS60/S105  
DS60/S80 ●  
DS51/S70 ●

