

Jost 158.6TH15

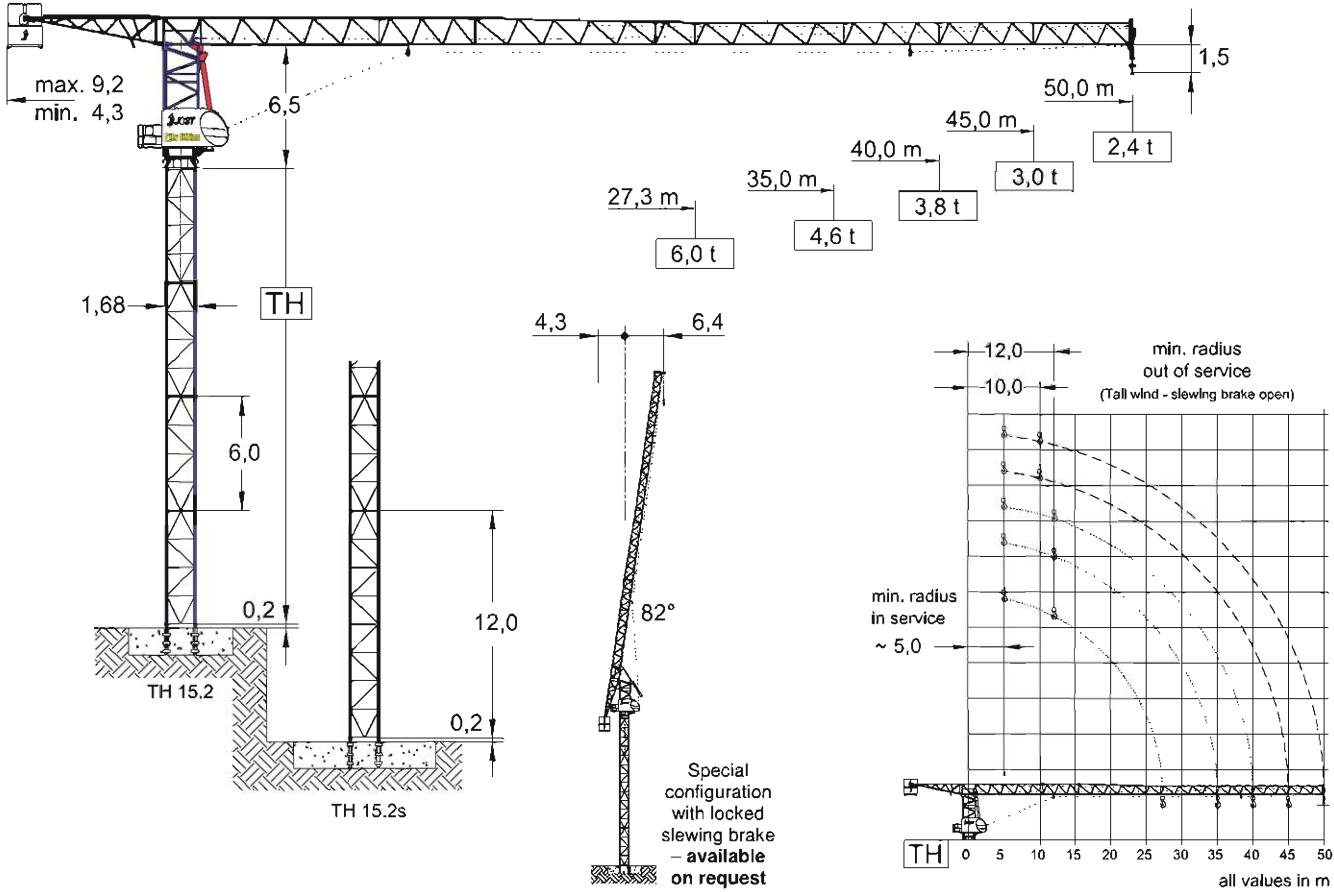

| Jib length (m) | 27,3 | 35,0 - 40,0 | 45,0 - 50,0 | |
|----------------|----------|-------------|-------------|--------|
| TH | TH 15.2 | 42,0 m | 42,0 m | 36,0 m |
| | TH 15.2s | 48,0 m | 48,0 m | 42,0 m |

| Radius & Capacity | | | | | | | | | | | |
|-------------------|------|----------|------|------|------|------|------|------|------|------|------|
| Jib | | max Load | | | | | | | | | |
| m | rope | t | m | 22 | 25 | 27,3 | 30 | 35 | 40 | 45 | 50 |
| 50 | | 3,0 | 40,9 | 3,00 | 3,00 | 3,00 | 3,00 | 3,00 | 3,00 | 2,70 | 2,40 |
| | | 6,0 | 21,5 | 5,68 | 5,12 | 6,00 | 4,21 | 3,57 | 3,08 | 2,70 | 2,40 |
| 45 | | 3,0 | 45,0 | 3,00 | 3,00 | 3,00 | 3,00 | 3,00 | 3,00 | 3,00 | 3,00 |
| | | 6,0 | 23,7 | 6,00 | 5,66 | 6,00 | 4,66 | 3,95 | 3,42 | 3,00 | 3,00 |
| 40 | | 3,0 | 40,0 | 3,00 | 3,00 | 3,00 | 3,00 | 3,00 | 3,00 | 3,00 | 3,00 |
| | | 6,0 | 26,1 | 6,00 | 6,00 | 6,00 | 5,17 | 4,39 | 3,80 | | |
| 35 | | 3,0 | 30,0 | 3,00 | 3,00 | 3,00 | 3,00 | 3,00 | 3,00 | | |
| | | 6,0 | 27,3 | 6,00 | 6,00 | 6,00 | 5,42 | 4,60 | | | |
| 27,3 | | 3,0 | 27,3 | 3,00 | 3,00 | 3,00 | | | | | |
| | | 6,0 | 27,3 | 6,00 | 6,00 | 6,00 | | | | | |

| Speeds 400 V - 50 Hz / 440 V - 60 Hz | | | | | | | |
|--------------------------------------|-----------|---------------|-----|-----|-----|-----|-----|
| Hoist unit 22 kW Frequency inverter | | | | | | | |
| Pmax | | 3,0 t - 6,0 t | | | | | |
| | Load [to] | 1,2 | 1,3 | 1,5 | 1,8 | 2,5 | 3,0 |
| | v [m/min] | 80 | 78 | 68 | 60 | 46 | 40 |
| | Load [to] | 2,4 | 2,6 | 3,0 | 3,6 | 5,0 | 6,0 |
| | v [m/min] | 40 | 39 | 34 | 30 | 23 | 20 |
| Drum capacity | | 340,0 m | | | | | |

| Hoist unit 30 kW Frequency inverter | | | | | | | |
|-------------------------------------|-----------|---------------|-----|-----|-----|-----|-----|
| Pmax | | 3,0 t - 6,0 t | | | | | |
| | Load [to] | 1,2 | 1,3 | 1,5 | 1,8 | 2,5 | 3,0 |
| | v [m/min] | 116 | 110 | 98 | 86 | 66 | 58 |
| | Load [to] | 2,4 | 2,6 | 3,0 | 3,6 | 5,0 | 6,0 |
| | v [m/min] | 58 | 55 | 49 | 43 | 33 | 29 |
| Drum capacity | | 340,0 m | | | | | |

| Motor | 15,0 kW FI | 1 x 4,4 kW | 2 x 5,0 kW |
|--------------------------|-------------|------------|--------------|
| t / v | 2,5 min | 0,77 rpm | 25,0 m / min |
| Power requirement | Hoist 22 kW | | 51 kVA |
| Upper part | Hoist 30 kW | | 60 kVA |